



## RCEXL Ignitions INSTRUCTIONS

[www.justengines.co.uk](http://www.justengines.co.uk)

Thank you for purchasing this RCEXL ignition from Just Engines Ltd.

**WARNING** – RCEXL ignitions were designed for use in model aircraft and should NEVER be used in a Human Carrying Vehicle!!

<p><b>Specifications:</b>          BPMR6F 14mm and BMR6A Ignition:          Input voltage 4.8-7v          Output voltage 12-16 kV          Max Draw @8000 rpm - 650 mA          Case - ABS with Nickel plate          Weight Single: less battery - 4.4oz          Weight Twin: less battery - 6.1oz          Plug size - 14MM NGK (BPMR6F)</p>	<p>CM6 10mm and ME-8 1/4 32 Ignitions:          Input voltage 4.8-7v          Output voltage 12-16 kV          Max Draw @8000 rpm - 650 mA          Case - ABS with Nickel plate          Weight Single: less battery - Single 4.4oz          Weight Twin: less battery - 6.1oz          Plug size - 10MM NGK (CM-6)</p>
---	--

### Selecting a Power Source

I.) 4.8 and 6v volt **NiCd/NiMh** Packs: The RCEXL Ignition version 2.0 is rated 4.8 - 6v. A 4 cell 4.8v pack with a minimum of 800 mAh is fine (1200mAh is better) and creates a hot spark. The RCEXL ignition version 2.0 runs most efficiently on 4 cell packs. Do not use an old Pack!! If it's not good enough for your receiver, it's not good enough for your ignition.

II) 6.4 Volt **Li-Fe(A123)** Packs 2cell **Li-Fe(A123)** The Volts Max of 7.2 volts. Nominal 6.6 Volts, **use a voltage regulator**. Or connect an IN4007 diode to reduce the voltage.

III.) 7.4+ Volt **Li-Poly** Packs: We have found that 2cell **Li-Poly** Packs at peak charge can be as high as 8 +v. If you are going to use a 2 cell **Li-Poly** Packs, you must use a voltage regulator. Or serially connect two IN4007 diode to reduce the voltage. The RCEXL ignition runs more efficiently on about 4.8-6Volts and will draw more current at around 8+v, as well as operate at a higher temperature. You also have a higher chance of RFI interference.

Basically, use the lowest voltage possible that allows you to still achieve the maximum rpm from the engine.

### Installation

**I.) Spiral Wrapping:** Use the supplied Spiral Wrapping included with your Ignition to protect the wires from heat and chafing. Wrap the braded Spark Plug Lead, Hall Sensor Harnesses and Battery Harnesses.

#### II.) Mounting:

Mount your Ignition in the engine bay if possible. Wrap the ignition in foam to reduce the effects of engine vibration on the circuitry just as you would do with your receiver. You can use the mounting tabs on the ignition but we recommend using zip ties or Velcro ties to secure it. Do not install your ignition in the fuselage. Do not use a metal throttle servo or steerable nose wheel pushrod. Keep the ignition as far away from your receiver as possible and never use the same power source to run your ignition and receiver jointly.

#### III.) Connecting the Battery:

The RCEXL ignition utilizes the Futaba style plugs and comes with an additional pigtail to make up an ignition switch harness if necessary. Be sure to follow the colour coding (Red +, Black -) when attaching



your battery and on / off switch to your ignition power leads (see fig.1). **The system is not reverse polarity protected.** Wrap your battery with foam and mount it as far away from the receiver as possible, preferably on the engine bay.

Fig. 1

#### IV.) Hall Effect Sensor:

Choose the Sensor housing the best suits your engine and determine the orientation of your magnet if unknown. **(fig. 2)** A quick way to determine the orientation is connect the hall sensor to the ignition, **insert a resistor spark plug** and connect your battery. Quickly pass the sensor over the magnet without stopping over the magnet, as this may damage the sensor. If the plug doesn't fire, flip the magnet or sensor over and repeat. An alternative to using the ignition would be to use our 'Sensor Test Kit'

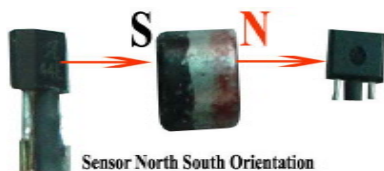
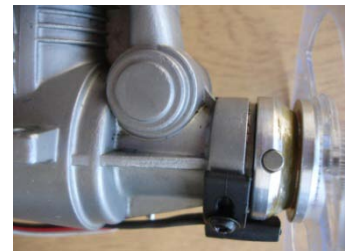

Fig. 2

#### V.) Magnet Installation:

Use a centre drill first and then drill a 3.9mm hole in the prop driver. Insert the magnet flush with the prop driver face – you can use a vice to squeeze it in. Do not use locktite and do not hammer the magnet in.



#### VI.) Assembling the Sensor Bracket:

Fully insert the sensor into the sensor housing. Use the supplied wedge to hold the sensor in its housing. **(fig. 3) Warning!! The wedge is designed to be a one way fit;** make sure you have the proper sensor orientation before inserting the wedge as it will be very difficult to remove! It may damage the bracket and even the sensor or lead. If the RCEXEL system is being used to replace a faulty system of another brand then you may well be able to use the existing sensor bracket fitted to the engine.



Fig. 3



If you are going to attempt to use your existing hall sensor, see (fig. 4) for the wire orientation. (Red +, Black -, white signal)

Fig. 4

## VII.) Timing:

Timing will vary from engine to engine. Usually, 28° ~30° before Top Dead Centre (TDC) is recommended. More than 30° advance will cause knocking and excessive vibration. Mount the Degree Wheel to the Crank Shaft (fig. 5). – You can cut out the template and make a backing from card or ply, then drill a hole for the crankshaft. Alternatively our 'Sensor Test Kit' is supplied with a plastic protractor and makes setting the timing very simple. Rotate the engine crankshaft so the piston is set at TDC. This can be ascertained by using a small wooden dowel to make contact with the piston top through the spark plug hole. Rotate the crankshaft back and forth to get TDC as close as possible. For absolute accuracy, a dial indicator can be used but is not necessary. After locating TDC without moving the Crank, move the Supplied Degree wheel so it reads 0 degrees and lock it down.



Turn the crankshaft clockwise (opposite to the engine rotation) until the wheel reads 28 degrees (or your required angle). Connect the Battery to the ignition insuring that the Spark Plug is not in the cylinder. The spark plug must be fitted in the plug cap. **Warning!!** Avoid turning the engine over with the ignition energized and without the spark plug being attached to the H.T. lead. Operating the ignition without a spark plug attached could damage the Hall sensor pickup. The plug will fire just as the rear edge of the magnet clears the sensor. You can check that everything is connected correctly by rocking the crankshaft so that the magnet passes under the sensor and a spark is generated.

### For Adjustable Magnet Rings:

Turn magnet fixed ring anti clockwise. When you see the plug firing, stop and lock down the ring, the correct ignition timing is now set (28° ~30°). The plug will fire as the magnet passes slightly past the Hall Sensor, this is a normal condition.

### Fixing of Sensor Bracket:

Try to use your existing hall sensor mounting holes, if this is a conversion (magneto to electronic or glow to petrol) you will need to estimate the hall sensor position at a 28 degree advance point (or your required advance angle) by using the degree wheel and drill and tap your own. The holes on the hall sensor housing are oval to allow for some adjustment. Fitting the sensor holder underneath the engine can keep it out of the way and less prone to damage.

*NB; obviously drilling holes in the crankcase means the engine must be stripped down and any warranty on the engine will doubtless be voided. It is possible to use alternative means to hold the Hall Effect sensor, such as jubilee clips or copper wire. Some examples of homemade systems are on our web site.*



This picture shows a Saito 1.25 with a homemade sensor holder made from an aluminium bracket mounted on the bottom crankcase web, with the sensor being affixed to the end with silicone sealant and a short length of heatshrink over the top.

## Additional notes for glow to spark conversions:

- Glow engines have a higher compression ratio than is required for spark ignition engines and therefore the fitting of an additional head shim or two will almost always be required to achieve a good result. Some engines, such as Saito do not use traditional style head shims and so a metal cylinder base shim between 0.6mm and 0.9mm can be used. You will need to remove the cylinder to fit the shim or make it in two halves with slotted holes and just lift the cylinder. Valve clearances should always be checked after removing heads from four stroke engines.
- An alternative to fitting shims is to experiment with retarding the ignition slightly, this can be done by having the hall sensor clamped on with a metal strap – hose clamp style or similar – in order to move it around the front housing to select the maximum timing position.

- All tubing used in the engine installation will need to be changed to petrol-proof tube, including the crankcase breather tube on four strokes.
- The carburettor does not need to be changed to a pumped carburettor if you did not need a pump for glow operation in the same set up. You will use exhaust pressure as before.
- A 20:1 petrol/oil mix is suitable using a good quality synthetic oil such as is used for outboard motors, motorcycles etc.

### Trouble Shooting your Ignition.

#### I.) Battery:

Check the voltage on your battery and make sure it's healthy and fully charged. Insure that the voltage is 6v or less to the ignition.

#### II.) Connections:

Check that all connections are correct from the battery, to the switch, to the ignition. Use a volt meter on the switch to ensure the ignition is getting power and the polarity is correct.

#### III.) Hall Effect Sensor:

Ensure that the orientation of the hall sensor is correct with the orientation of your hub magnet. If you used your existing hall sensor, make sure that the wire orientation (fig. 4) is correct

### Safety Precautions.

Never power the ignition with the plug in the engine when you're working on your engine, it could fire. Always wear a glove when starting your engine. After turning off your ignition, beware that the ignition could still have a charge and fire the engine. Always range check your model.

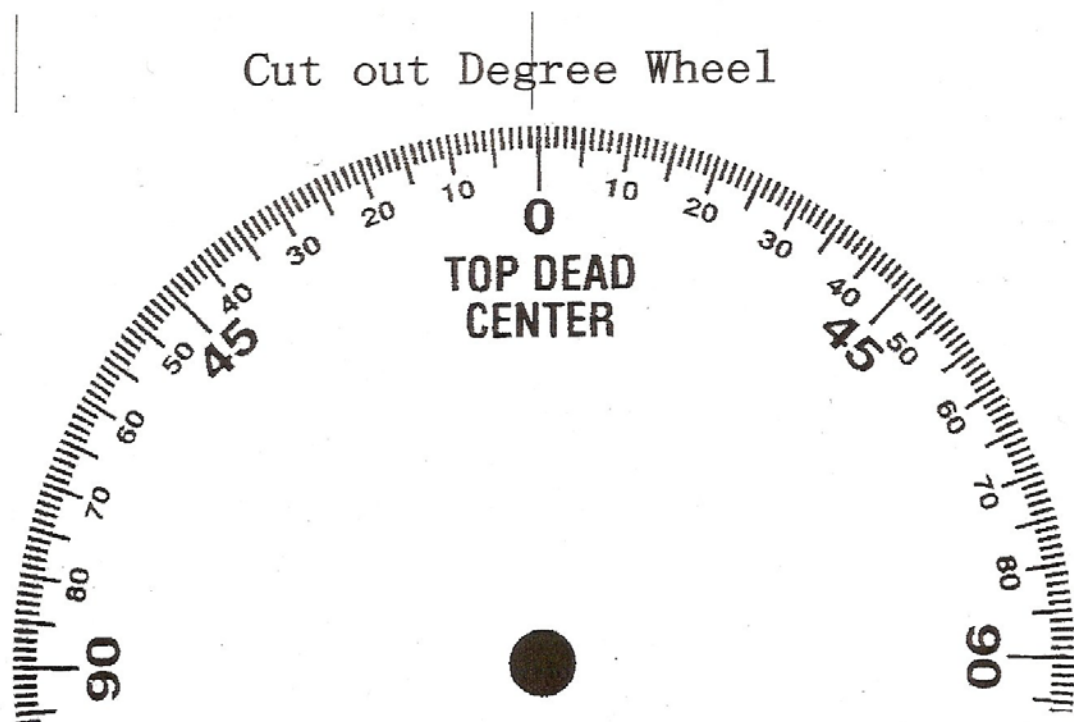

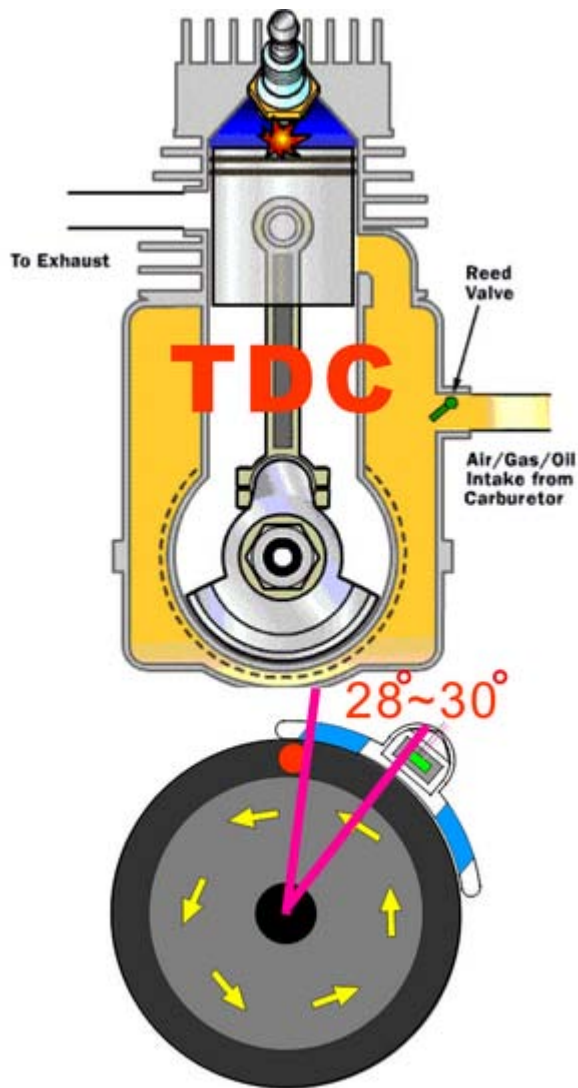

RCEXEL ignitions are fitted to your engine at your own risk and Just Engines Ltd accepts no responsibility for any damage resulting from the fitting and/or running of the ignition system on new or used engines.

©Just Engines Ltd 2010

Newby Cross Farm, Newby Cross Carlisle CA5 6JP. [www.justengines.co.uk](http://www.justengines.co.uk)